

## Accessories

## Control Set VGU

### Description

The control set VGU is used for testing and adjusting of the precharge pressure of bladder-, piston-, and diaphragm accumulators. The equipment fits on all OLAER-accumulators and such with equivalent connection situation, no matter whether 5/8" , 7/8" (used mainly in Germany) VG 8 or for all commercial accumulators with filling connection M28 x 1,5. It is screwed on the gas valve of the accumulator and connected with the attached hose to a commercial nitrogen vessel. If the maximum allowable operating pressure of the accumulator is lower than the maximum allowable operating pressure of the nitrogen vessel, a pressure-reducing valve with gas relief valve must be inserted.

The adjusting pressure of the gas relief valve may not be higher than the maximum allowable operating pressure of the accumulator.

The complete control set consists of:

- Control set for connection M28 x 1,5 with inside hexagonal
- Charging hose, length estimated 2,5 m
- Adapter for gas valve
  - 7/8" – 14 UNF
  - 5/8" – 18 UNF
  - 0,305" – 32 NPT (VG 8)
- socket wrench
- plastic protection suitcase

### Handling

Before each examination of change of the gas filling pressure the accumulator is to be relieved on the liquid side. To each control set detailed operating instructions in three languages (German, English, French) is attached.

With the control set you can

**check**  
**reduce**  
**raise**  
 the precharge pressure.

The union nut with M 28 x 1,5 at the control set is usable for examining our diaphragm accumulators and all other gas valves with same connecting thread.

For bladder- and piston accumulators additionally the appropriate adapter is to be used. Meaningfully this is set first on the gas valve and then the control set is to be put on. The spindle in the control set is to be turned only so far clockwise until the manometer indicates a pressure. Then the gas valve is opened enough.

### Check or reduce of gas pressure

In this case the tube does not need to be connected. The equipment has a check valve which prevents that gas can leak out of the tube connection.

### Increase of the gas pressure

To increase the gas pressure sufficiently nitrogen bottles with appropriate pressure have to be available. If this is not the case, the desired higher pressure can be brought in by a nitrogen charger.

The relevant safety regulations are to be considered. The used nitrogen should have at least a purity of 99,8 % . The commercial nitrogen generally fulfills these conditions.

### Attention!!!

**For filling use only inert gases, never oxygen or air!**  
**DANGER OF EXPLOSION!!!**



### Type designation

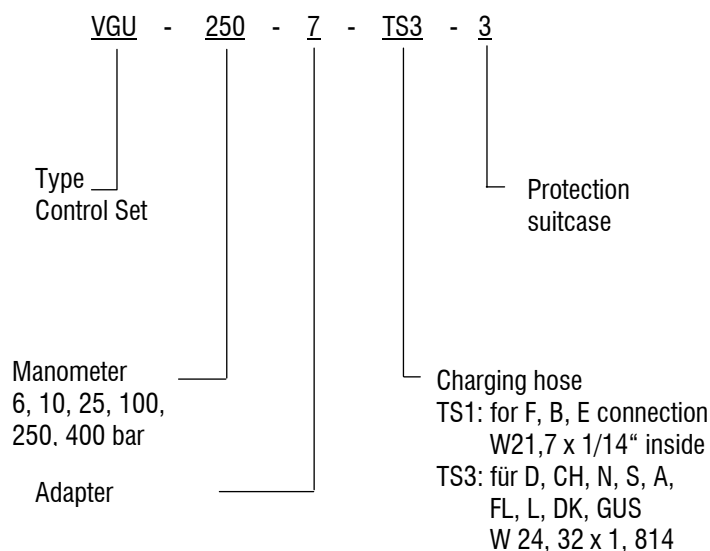

**The following connecting adaptors for foreign nitrogen bottles are available:**

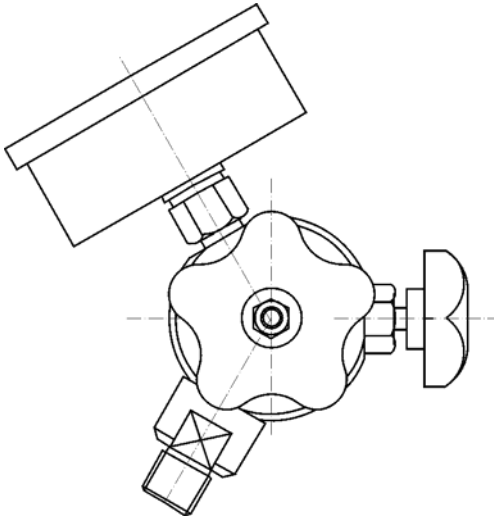

GB/AUS	R 5/8" external
USA	24,51 x 1/14" external
Italy	21,7 x 1/14" external
Japan	22 x 1/14" internal
Japan	W 23 x 1/14" external
Brazil	R 1/2" internal
F,B,E	21,7 x 1/14" internal
China	M 22 x 1,5 internal
China	5/8" internal
Malaysia	G 7/8" external
Trinidad	7/8" - 14 UNF external
Bulgaria	3/4" internal
The Philippines	W 23 x 1/14" left

